

TMG
紧凑型马达减速机
TMG compact motor gear



紧凑型马达减速机TMG
Compact Motor Gear



注塑机TIN系列
Gearbox TIN series



注塑机KIN系列
Gearbox KIN series



行星减速机
Planetary Speed Reducer



橡胶胶齿轮箱专业制造商

台南总部
台南科学园·善化区

传仕精密机械股份有限公司

- 电话：+886-6-5818117
- 传真：+886-6-5819117
- evachen@transcyko.com
- 台南市善化区兴农路69巷31弄17号 74160

南京制造中心

南京传仕重工科技有限公司

- 电话：+86-025-566-07388
- 传真：+86-025-566-03188
- emma@transcyko-transtec.com
- 南京市溧水区和凤机电产业园凤鸣路28号 211216

NO.TRANSCYKO-2022-8-TMG

TMG驱动运用于：

挤出机
注塑机
搅拌机
破碎机
研磨机等等

型号范围 TMG 05-TMG 601
扭矩范围 500 Nm-150,000 Nm

南京传仕重工科技有限公司
传仕精密机械股份有限公司

www.transcyko.com
www.transcyko.com.cn

TMG 马达减速机

● 在最小的空间里提供了巨大的性能。发展这种紧凑型驱动器的构想是在一个新的电机驱动中实现如多柱塞式液压马达的高性能密度。

● 该系列的主要特点是四个紧实的三相电动机，围绕着一个中心孔，安装在一个机构中。电动机的四个小齿轮啮合一个共同的驱动齿轮，可以避免侧向力作用在驱动轴承上，以及较低的圆周速度，确保及其安静的运转。

● TMG 马达采用水冷作为标准来排除马达产生的热能。除了外部的输入输出水管，TMG 内部冷却水流不需要额外的管路来输送冷却水。

● 四台马达的电气特性与普通的三相交流异步马达相同。马达组件专为结合变频器运行而设计。诸如温度传感器之类的保护装置是标准配置。另可根据需求选择使用于速度控制的编码器。

● TMG 系列最初设计用于驱动塑料机械，现今在许多领域发挥着重要作用。这种减速机适用于高性能和高扭矩的应用上，诸如混合器，搅拌器，球磨机，碎纸机或挤出机等。

TMG motor reducer

Provides great performance in minimal space. The idea of developing this compact driver is to realize high performance density such as multi piston hydraulic motor in a new motor drive.

The main feature of this series is that four compact three-phase motors are installed in a mechanism around a central hollow hole. The four pinion gears of the motor mesh with a common drive gear, which can avoid the lateral force acting on the drive bearing and the low circumferential speed, ensuring the quiet operation.

The TMG motor uses water cooling as the standard to eliminate the thermal energy generated by the motor. In addition to the external input and output water pipes, the internal cooling water flow of TMG does not need additional pipes to convey the cooling water.

The electrical characteristics of the four motors are the same as those of ordinary three-phase AC asynchronous motors. The motor assembly is designed for operation in combination with the frequency converter. A protection device such as a temperature sensor is a standard configuration. In addition, the encoder used for speed control can be selected according to demand.

The TMG series was originally designed to drive plastic machinery and now plays an important role in many fields. This reducer is suitable for high performance and high torque applications, such as mixers, blenders, ball mills, shredders or extruders.

结构和功能 (Structure and function)

TMG 马达减速机由两个子部件组成，即马达部件和齿轮部件。

TMG motor reducer is composed of two sub parts, namely motor part and gear part.

齿轮部分：1 段，2 段或 3 段减速
Gear part: 1-stage, 2-stage or 3-stage reduction

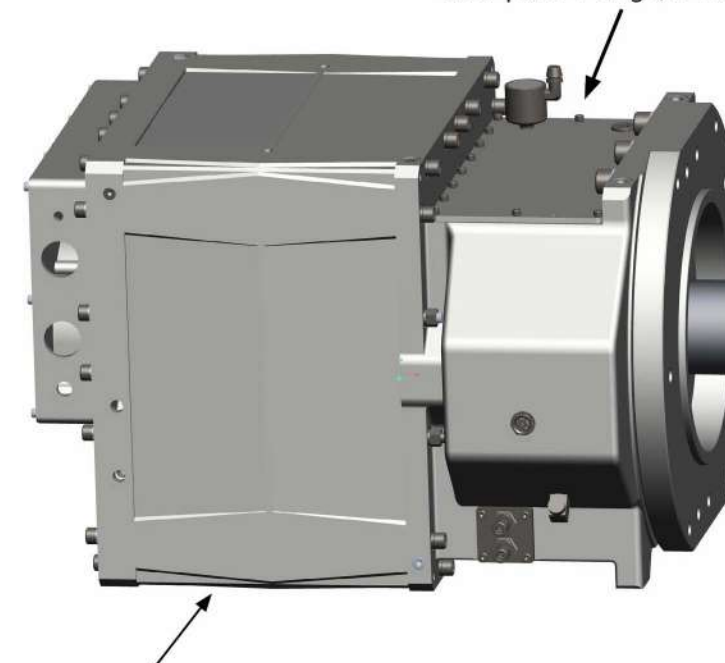

马达部分：一体式马达或四个模块化马达
Motor part: integrated motor or four modular motors

马达部分

马达部分是带有四个单马达的多马达单元。电动机组件围绕中心孔对称排列。各个马达内部绕组分别做星形连接，然后并联至电源端子上。紧凑的尺寸和小的转子直径使马达单元有高的动态反应。马达转子和小齿轮轴之间结合连接到紧凑齿轮箱单元。这种结合为摩擦式锥形连接 - 将转子当做锥形凹槽。

Motor part

The motor part is a multi motor unit with four single motors. The motor components are arranged symmetrically around the central hollow hole. The internal windings of each motor are connected in a star shape and then connected to the power supply terminal in parallel. The compact size and small rotor diameter make the motor unit have high dynamic response. The coupling between the motor rotor and the pinion shaft is connected to a compact gearbox unit. This combination is a friction type tapered connection - the rotor is treated as a tapered groove.

齿轮部分

齿轮乃是具有对称结构的斜齿轮。齿轮轴和齿轮盘经硬化和研磨。TMG 马达减速机有单端、两端和三段减速。所有类型都有一个中央齿轮，标配一个中空输出轴。在这种设计中，输出轴齿合力在径向和圆周方向彼此平衡，因而减轻了输出轴承的负担并获得最佳效率。多啮合确保了高度的优异性能。传统驱动方式相比，TMG 紧凑型马达减速机缩小了相当大的安装空间。

Gear part

The gear is a helical gear with symmetrical structure. The gear shaft and the gear plate are hardened and ground. TMG motor reducer has single stage, two stages and three-stage reduction. All types have a central gear with a hollow output shaft as standard. In this design, the meshing forces of the output shaft are balanced with each other in the radial and circumferential directions, thus reducing the load of the output bearing and obtaining the best efficiency. Multi engagement ensures a high degree of excellent performance. Compared with the traditional drive mode, the TMG compact motor reducer reduces a considerable installation space.

1 段减速版本 (Deceleration version of section 1)

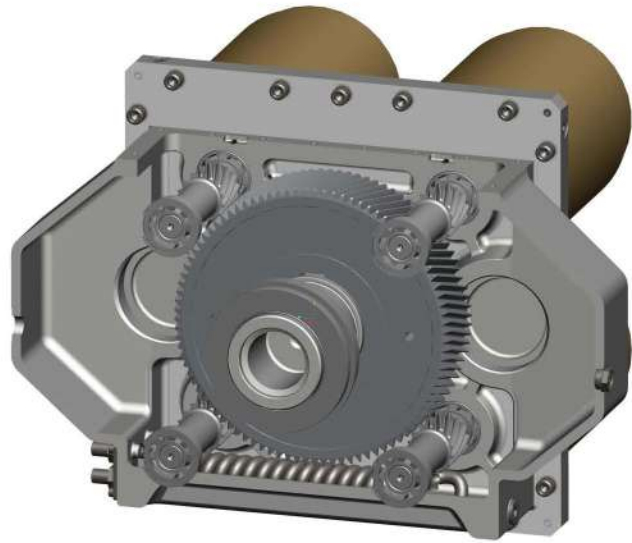

四组齿轮啮合
四个斜齿轮驱动一个共同的输出齿轮盘
最高减速比可达 $i = 12$
标准版含中空输出轴

Four sets of gears mesh
Four helical gears drive a common output gear plate
The maximum reduction ratio can reach $i = 12$
Standard Version, including hollow output shaft

2 段减速版本 (Deceleration version of section 2)

2 x 2 齿轮啮合
两个斜齿轮各自驱动一个共同的中间齿轮盘
通过齿轮轴将中间齿轮盘传送到共同的输出齿轮盘上
最高减速比可达 $i = 47$
标准版含中空输出轴

2 x 2 gear engagement
The two helical gears each drives a common intermediate gear plate
The intermediate gear plate is transmitted to the common output gear plate through the gear shaft
The maximum reduction ratio can reach $i = 47$
Standard Version (including hollow output shaft)

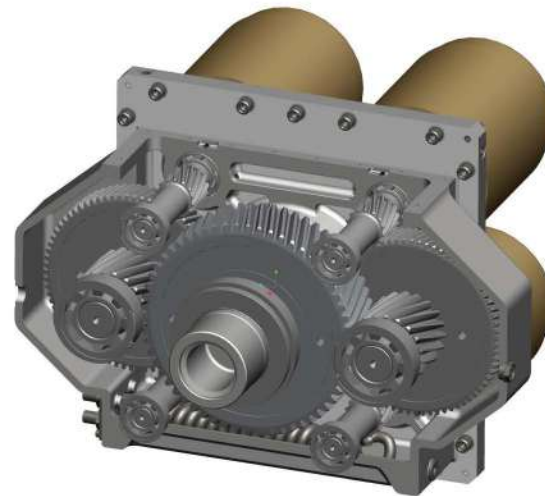

数据表 (Data sheet)

TMG型号 TMG model	05	10	20	30/31	60/61	120/121	240/241	400/401	601
额定马达数据 Rated motor data	400 V / 50 Hz / 1500rpm								
额定功率 P_N (kW) Rated power P_N (kw)	6	18	22	60	88	147	256	440	1000
额定电流 I_N (A) Rated current I_N (A)	13.5	37	50	121	176	284	466	810	1760
额定扭矩 M_N (Nm) Rated torque M_N (Nm)	40	120	148	392	576	964	1660	2830	6440
结合变频器运转 Combined with frequency converter operation	400 V / 87 Hz / 2600rpm								
最大功率 P_{max} (kW) Maximum power P_{max} (kw)	10.5	27	33	90	132	221	384	660	-
额定电流 I_N (A) Rated current I_N (A)	23.5	63	87	210	305	492	810	1660	-
额定扭矩 M_N (Nm) Rated torque M_N (Nm)	35	105	127	338	496	830	1430	2440	-
齿轮数据 Gear data	输出扭矩取决于齿轮减速比和驱动功率 The output torque depends on the gear reduction ratio and the drive power								
1段最大扭矩 (Nm) Maximum torque of section 1 (Nm)	500	1500	3000	4000	8000	15000	20000	28000	60000
2段最大扭矩 (Nm) Maximum torque of section 2 (Nm)	1200	3000	4000	8000	16000	30000	48000	68000	150000
3段最大扭矩 (Nm) Maximum torque of section 3 (Nm)	-	-	-	-	16000	30000	48000	160000	-
1段减速比 Reduction ratio of section 1	2,5 / 3,1 / 3,9 / 4,9 / 6,1 / 7,7 / 9,6 / 10,6 / 12								
2段减速比 Reduction ratio of section 2	11,9 / 13,8 / 15 / 18,8 / 20 / 21,5 / 23,5 / 27,5 / 29 / 33,2 / 37,2 / 47,5								
3段减速比 Reduction ratio of section 3	23,5 / 43,3 / 45,8 / 54 / 66,4 / 74,4 / 81,9 / 84 / 100,8								

TMG 系列优点 (Advantages of TMG series)

一、在相同性能下与传统的三相交流马达结合齿轮箱比较，无论和传统的 U 形或 Z 形安装相比，TMG 安装具有相对极短的设计。这里的一大优点是减少了齿轮部分所需的空间，从而降低了齿轮油的需求量。

二、电机使用水冷系统，冷却效果较好且降低噪声。

三、齿轮的分流，降低齿轮的变形及增加强度。

1、Compared with the traditional three-phase AC motor combined with gear box under the same performance, the TMG installation has a relatively shorter design compared with the traditional U-shaped or Z-shaped installation. A major advantage here is that the space required for the gear part is reduced, thereby reducing the demand for gear oil.

2、The motor uses a water cooling system, which has good cooling effect and reduces noise.

3、The diversion of gears reduces the deformation of gears and increases the strength.

主要尺寸 (Main dimensions)

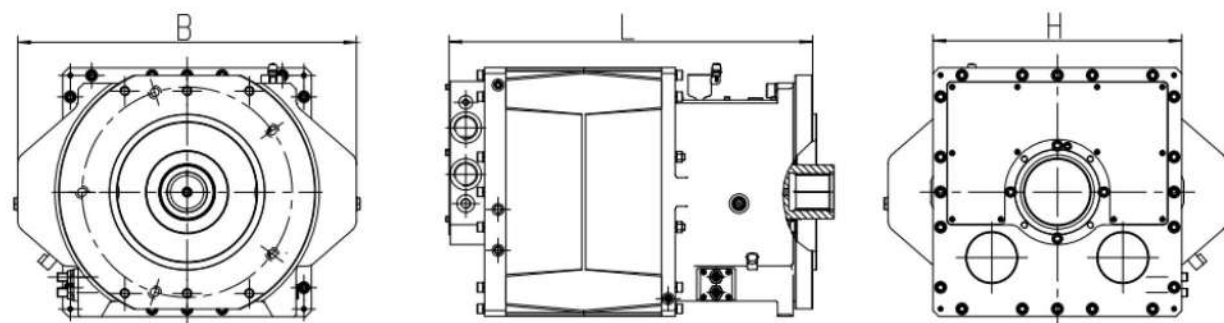

TMG型号 TMG model	05	10	20	30/31	60/61	120/121	240/241	400/401	601
B(mm)	350	430	470	570	710	870	980	-	-
L(mm)	460	460	485	560	770	880	990	-	-
H(mm)	280	340	380	450	540	630	700	-	-

重量 (Weight)

TMG型号 TMG model	05	10	20	30/31	60/61	120/121	240/241	400/401	601
标准1段(kg) Standard section 1 (kg)	55-70	150-170	150-180	365-470	750-830	1160-1850	-	-	-
标准2段(kg) Standard section 2 (kg)	85-100	170-190	170-200	415-520	850-930	1290-1980	2000-2340	3200-3500	-
含止推轴承1段(kg) Including thrust bearing 1 section (kg)	65-80	175-195	210-240	465-570	870-950	1410-2000	-	-	-
含止推轴承2段(kg) Including thrust bearing 2 section (kg)	95-110	195-215	240-270	515-620	970-1050	1540-2130	2400-2740	4000-4200	-

注意事项: 上表为参考值, 实际可能因版本不同而异

Note: the above table is the reference value, which may vary according to the version

TMG 中空轴驱动 (TMG hollow shaft drive)

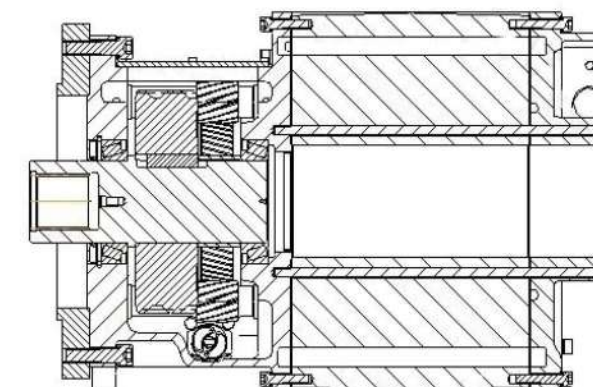

● 对于所有滑动应用的理想设计。中空轴取代联轴器, 并且有键槽及栓槽的中空轴可选择。中空轴的设计能容许从马达端自由的通过驱动轴。对于具有高侧向力的需求应用, 如搅拌机、混合机, 需特别注意马达侧的轴承支撑位置。而 TMG 的设计正好具有最佳的空间位置。

Ideal design for all sliding applications. Hollow shaft replaces coupling, and hollow shaft with keyway and bolt groove can be selected. The hollow shaft is designed to allow free passage of the drive shaft from the motor end. For applications requiring high lateral force, such as mixers and blenders, special attention should be paid to the bearing support position on the motor side. And the design of TMG just has the best spatial position.

TMG 挤出机驱动 (TMG extruder drive)

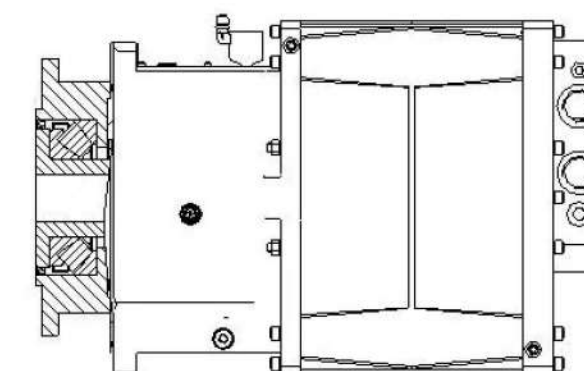

● 单螺杆压出机系列。此应用结合了 TMG 所有的优点。非常简短的设计, 无需 U 型或 Z 型的马达配置。能从前端或后端自由的通过驱动轴以便螺杆拆卸。推动挤出机设计技术向前推进。

Single screw extruder series. This application combines all the advantages of TMG. Very short design, no U-type or Z-type motor configuration is required. It can freely pass through the drive shaft from the front end or the rear end for screw removal. Push the extruder design technology forward.